

The Promat logo is displayed in white text on a blue rectangular background. The background of the entire page is a photograph of a hand holding a tablet. The tablet screen shows a 3D architectural rendering of a modern office interior with large glass walls, a wooden ceiling with slats, and a conference table with chairs. In the background, a hand-drawn architectural plan is visible, featuring labels such as 'ARCH', 'LINEN', 'COATS', 'W.H. PLATFORM', and 'W.I.C. CARPET'.

# Promat

## Promat SYSTEMGLAS® Advenerat Specifiers Guide

**Specified for a reason®**

[www.promat.com/industry](http://www.promat.com/industry) | 0800 588 4444 | [industryuk@promat.co.uk](mailto:industryuk@promat.co.uk)

etex industry

# About Promat UK

Promat UK is an acknowledged leader in the manufacture and supply of fire, thermal and acoustic solutions. We are proud to provide a range of products that are trusted, proven and installed worldwide, across a diverse range of industries and applications. Promat UK is a division of Etex Industry who are a key part of the global Etex Group who have a presence in 45 countries, operating 107 production sites and employing more than 15,000 skilled and dedicated professionals.

## Promat SYSTEMGLAS®

Promat SYSTEMGLAS® was the first butt jointed glazed fire protection system to be developed for the UK market with a history of over 30 years. This system can either be framed or butt jointed so architects can achieve unlimited runs of aesthetically appealing glazing without any compromise to the fire resistance. All components are tested together as a certified system and there are a variety of framing options to suit the interior of any building. SYSTEMGLAS® complies with, or exceeds, recognised UK and European standards and regulations relating to passive fire protection. The use of fully trained Promat-approved installers ensures complete peace of mind that it has been installed in line with Promat guidelines along with maximum reassurance of supply chain traceability.

### The SYSTEMGLAS® Options

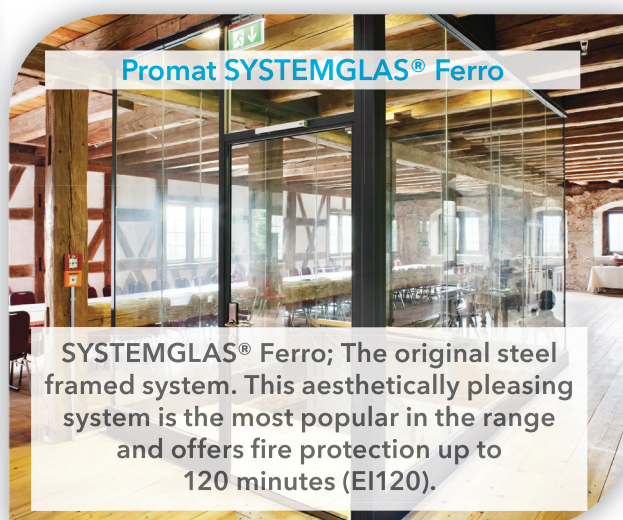
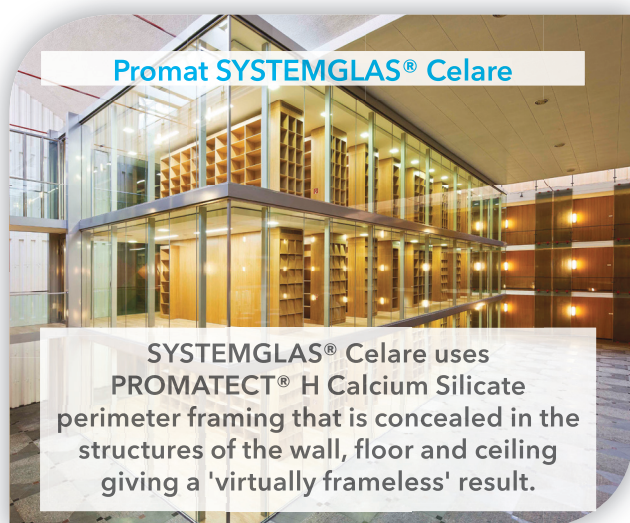

## Why SYSTEMGLAS® is 'Specified for a reason®'

- + The Glass, Framing and components are fire tested together as a complete certified system.
- + Fire rated from 30 minutes integrity and insulation (EI30) up to 120 minutes (EI120).
- + Produced in-house by Promat for maximum supply chain traceability.
- + As part of the 360° wheel of assurance, the system is fitted by Promat-approved installers and a Certificate of Conformity is issued by Promat UK.
- + Butt jointed glazing for maximum light transmission and a contemporary appearance.
- + Project support by Promat UK from specification through to installation.
- + A history of over 30 years producing fire rated glazing systems across the world.

## 360° Wheel of Assurance

To prevent product substitution and poor installation, Promat UK introduced the 360° Wheel of Assurance for SYSTEMGLAS®. Promat's technical experts provide guidance on the right approach at the design and specification stage. The system is manufactured in-house to ensure all cutting and processing is completed to the highest standard. Concluding the wheel, Promat inspects the system on completion to ensure it has been installed in accordance with Promat recommendations and a certificate of conformity is provided.

Promat can provide this assurance because it is in complete control of the design and manufacture process, and has in-depth knowledge of the installation requirements. This means supply chain risks, such as product substitution or poor installation, can be eliminated.



# SYSTEMGLAS® Advenerat EI30

SYSTEMGLAS® Advenerat is an innovative fire rated glazing system specifically designed to complement the decor of any building. The Promat fire resistant PROMATECT® H Calcium Silicate perimeter framing system can be overlaid, painted or powder coated to provide a variety of styles and effects in combination with the butt jointed glass.

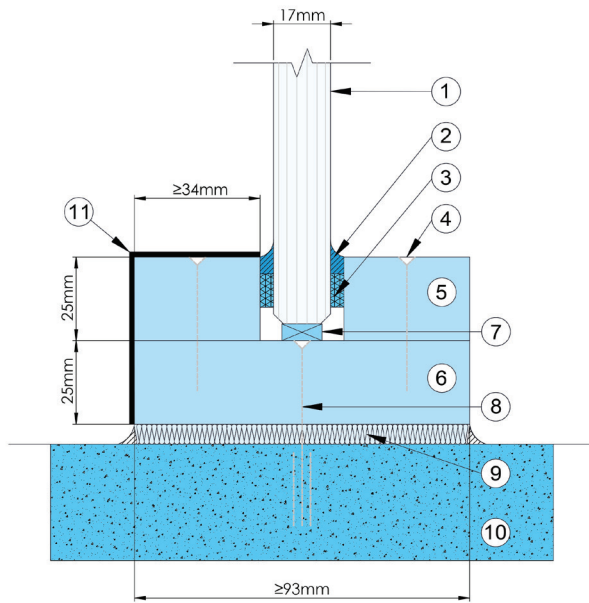

Certifire CF5452

- 1 SYSTEMGLAS®
- 2 SYSTEMGLAS® Silicone sealant
- 3 Self-adhesive neoprene glazing tape, 10x3mm
- 4 Bead fixings, steel screws, 3.5x45mm at maximum 300mm centres
- 5 Glazing Beads, PROMATECT® H 25mm thick x 34mm wide
- 6 Perimeter frame, PROMATECT® H 25mm thick x 93mm wide
- 7 PROMATECT® H setting blocks, 6mm thick x 17mm wide x 150mm long
- 8 Masonry fixing, steel anchor or similar
- 9 Compressed rock fibre 45kg/m<sup>3</sup> density 10mm thick x 93mm wide
- 10 Solid wall, floor or soffit with fire resistance equal to, or greater than that of the glazing system
- 11 Optional cladding

## SYSTEMGLAS® Advenerat EI30 Modular Dimensions (Larger sizes available on request)

		Height (mm)	Width (mm)
VERTICAL		3000	1000
HORIZONTAL		1750	3150

Thicknesses are subject to tolerances

### EI30 Glazing Specification

- Sizes outlined above. Contact us for larger sizes
- 39 dBRw sound reduction
- 2B2 safety rating
- 40kg/m<sup>2</sup>
- 84% light transmission (internal grade)
- External grade available for UV protection

### Additional Glass Options

- Low Iron available
- External grade for UV stability
- Screen manifestation
- Enhanced acoustics (using EG products)

# SYSTEMGLAS® Advenerat EI60

SYSTEMGLAS® Advenerat is an innovative fire rated glazing system specifically designed to complement the decor of any building. The Promat fire resistant PROMATECT® H Calcium Silicate perimeter framing system can be over clad, painted or powder coated to provide a variety of styles and effects in combination with the butt jointed glass.

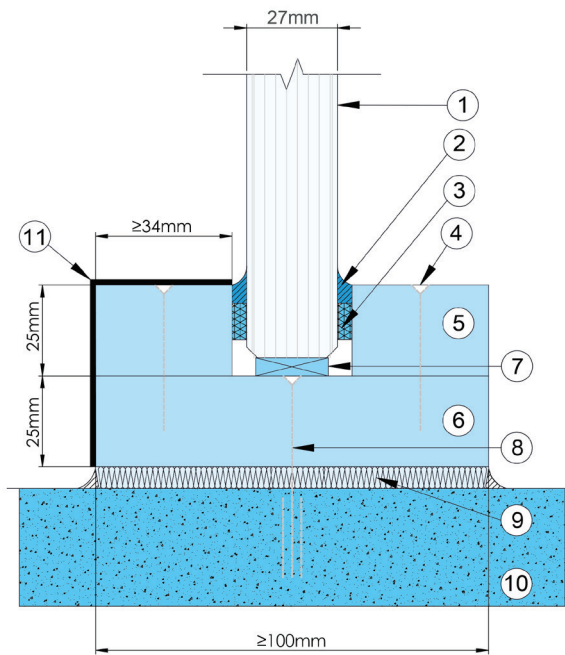

Certifire CF5452

- 1 SYSTEMGLAS®
- 2 SYSTEMGLAS® Silicone sealant
- 3 Self-adhesive neoprene glazing tape, 10x3mm
- 4 Bead fixings, steel screws, 3.5x45mm at maximum 300mm centres
- 5 Glazing Beads, PROMATECT® H 25mm thick x 34mm wide
- 6 Perimeter frame, PROMATECT® H 25mm thick x 106mm wide
- 7 PROMATECT® H or hardwood setting blocks, 6mm thick x 25mm wide x 150mm long
- 8 Masonry fixing, steel anchor or similar
- 9 Compressed rock fibre 45kg/m<sup>3</sup> density 10mm thick x 100mm wide
- 10 Solid wall, floor or soffit with fire resistance equal to, or greater than that of the glazing system
- 11 Optional cladding

## SYSTEMGLAS® Advenerat EI60 Modular Dimensions (Larger sizes available on request)

		Height (mm)	Width (mm)
VERTICAL		3000	1000
HORIZONTAL		1576	3051

Thicknesses are subject to tolerances

### EI60 Glazing Specification

- Outlined above. Contact us for larger sizes
- 40 dBRw sound reduction
- 1B1 safety rating
- 60kg/m<sup>2</sup>
- 81% light transmission (internal grade)
- External grade available for UV protection

### Additional Glass Options

- Low Iron available
- External grade for UV stability
- Screen manifestation
- Enhanced acoustics (using EG products)

# SYSTEMGLAS® Glass Butt Joint Options (EI30-EI60)

Clear butt joints are available where angles and corners are required. These are available for EI30 and EI60 fire ratings SYSTEMGLAS® Celare, Advenerat, Ferro and Ligna framing.

## In Line Option

- 1 SYSTEMGLAS®
- 2 Silicone sealant

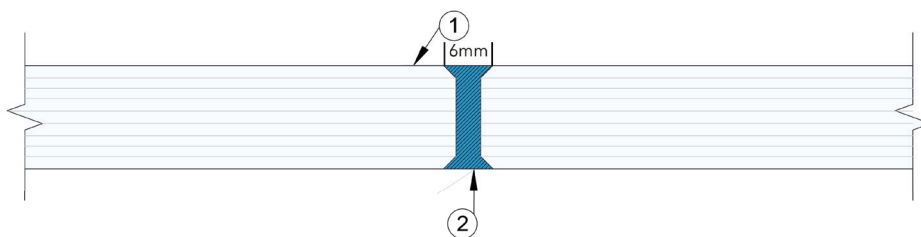

90°

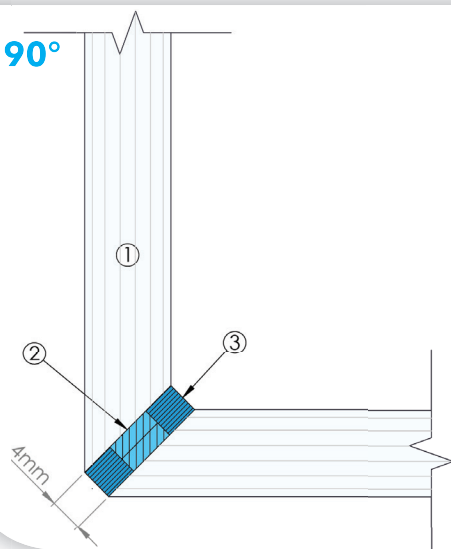

- 1 SYSTEMGLAS® EI30
- 2 Kerafix FXL220
- 3 Dow Corning Firestop
- 4 Optional covers (Plastic, steel or aluminium)

## Variable (90°-180°)

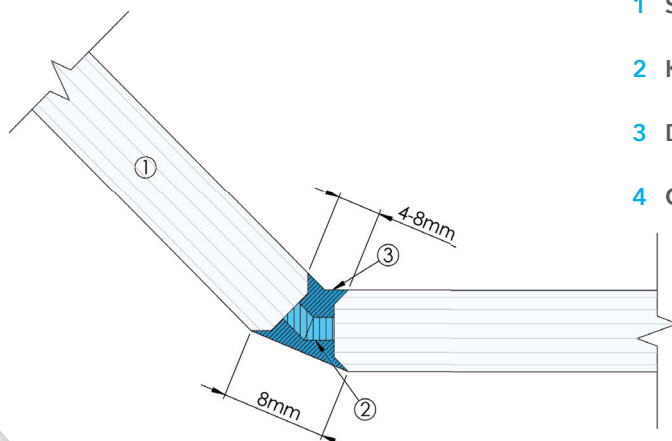

- 1 SYSTEMGLAS® (EI30 illustrated)
- 2 Kerafix FXL220
- 3 Dow Corning Firestop
- 4 Optional covers (Plastic, steel or aluminium)

# 'Specified for a reason®' Campaign

## Specified for a reason®

Promat initiated the hard-hitting 'Specified for a reason®' campaign to challenge product substitution in the industry and emphasise the importance of using a fully certified system.



**Promat** Glazing for Life®

Are your contractors seriously considering switching the specification?

Story to be continued...

Even the slightest change to your passive fire protection specification could result in catastrophic failure. Stick with Promat SYSTEMGLAS®. Find out more at [promat-glass.co.uk/specifiedforareason](http://promat-glass.co.uk/specifiedforareason).

**Promat SYSTEMGLAS® Specified for a Reason**

Promat UK Ltd | 0800 588 4444 | [sales@promat.co.uk](mailto:sales@promat.co.uk)

etex industry



**Promat** Glazing for Life®

The fire resistant glazing system fails. Who in the supply chain allowed that to happen?

Story to be continued...

If fire resistant glazing is not designed, manufactured and installed correctly, it's just glazing. Change the fire glass specification and lives are at stake - stick with Promat SYSTEMGLAS®. Find out more at [promat-glass.co.uk/specifiedforareason](http://promat-glass.co.uk/specifiedforareason).

**Promat SYSTEMGLAS® Specified for a Reason**

Promat UK Ltd | 0800 588 4444 | [sales@promat.co.uk](mailto:sales@promat.co.uk)

etex industry



**Promat** Glazing for Life®

You saved a few quid by changing the specification. Was it really worth the risk? Don't let it happen.

Story to be continued...

If you change a fire glass specification you could face prosecution if the worst happens. Stick with Promat SYSTEMGLAS®. Find out more at [promat-glass.co.uk/specifiedforareason](http://promat-glass.co.uk/specifiedforareason).

**Promat SYSTEMGLAS® Specified for a Reason**

Promat UK Ltd | 0800 588 4444 | [sales@promat.co.uk](mailto:sales@promat.co.uk)

etex industry

## Project Snapshots

### Engineering Company, Germany.

Promat SYSTEMGLAS® Advenerat provided up to 30 minutes (EI30) fire protection in the boardroom of a leading German engineering company. The PROMATECT® H framing is over clad with a polished aluminium trim and along with the butt jointed glazing creates a futuristic effect and an open environment.



# Project Snapshots

## Dublin Landings, Ireland.

Promat SYSTEMGLAS® Ferro provided assured passive fire protection for a spectacular central atrium in one of Dublin city centre's largest and most prestigious commercial development. Large spans of butt jointed glass in combination with the steel framing offers a contemporary feel with up to 30 minutes (EI30) fire protection.



## Walled Garden, Devon.

Promat SYSTEMGLAS® Celare was used to provide fire protection on a revolutionary new-build Passivhaus project in Devon. The PROMATECT® H framing is fully concealed in the walls and floor to offer a 'virtually frameless' solution for ultra-modern slim internal windows, which would have been difficult to achieve with a conventional system due to the slim sizes.







## Benefit from 60 years of experience

Promat is the leading reference and pioneer in the fields of **fire, thermal, and acoustic protection**. With a strong global presence and 60 years of experience, innovation and know-how, Promat UK is the first choice for fire rated glazing systems.

## Global sales & technical support

Promat has more than **1,300 employees** spread over **13 factories, 40 sales offices** and **2 innovation centres** worldwide. The company is part of Etex Industry, a division of the Belgian industrial group Etex, specialised in the manufacture and supply of construction materials.

## Sales offices and production facilities

Australia, Austria, Belgium, Brazil, Bulgaria, China, Chile, Colombia, Czech Republic, Denmark, France, Germany, Hong Kong, Hungary, India, Ireland, Italy, Japan, Kazakhstan, Lithuania, Malaysia, The Netherlands, Peru, Poland, Romania, Russia, Serbia, Singapore, Slovakia, South Africa, Slovenia, South Korea, Spain, Switzerland, UAE, UK, USA.

## Contact us now

Contact us with your requirements. We look forward to advising you on your projects.

Promat UK Ltd • B1 The Innovation Centre • Heywood Distribution Park • Pilsworth Road • Heywood • OL10 2TS  
+44 (0)800 588 4444 • [industryuk@promat.co.uk](mailto:industryuk@promat.co.uk)

[www.promat.com/industry](http://www.promat.com/industry)